

CONTEMPORARY  
**LIGHTING**

---

2015-2016

LIGHT  
YEARS



# LIFE, LIGHT & LAMPS

---

Light is the fundamental precondition for reproducing shape and colour and for creating atmosphere in any layout. Light gives a space life and it is a basic prerequisite in the creation of environments that make people feel cosy.

Lighting is a passion for our team at Lightyears. Lighting is our line of business, our work and our hobby. We experience light, functionality and aesthetics as a natural trinity that forms the essence of our design. The hallmark of all our lamps is the ability to provide good, functional light that responds to a person's need for proper illumination. We are proud of our Scandinavian heritage and we work purposefully with a view to adding new, well-written chapters to modern Danish design.





# CONTENTS

---

8 PENDANTS

































68 TABLE & FLOOR LAMPS

86 WALL LAMPS

96 OUTDOOR LAMPS

102 REFERENCES

# PRODUCTS

	AEON ROCKET	ATOMHEART	AVION	BRANCUSI	BULBFICTION	CALABASH	CARAVAGGIO	CARAVAGGIO MATT	CARAVAGGIO OPAL	CARAVAGGIO WALL	CONCERT	HL	JUCY	LULLABY	MINGUS	MONDRIAN	ORIENT	PALLAS	PRIMULA	PHARAOH	RADON	TAKERU	VOLUME	
PENDANTS	 8 34 ●●	 66	 10	 64	 62	 38 ●●●●	 22 ○●●	 14 ●●●●	 28	 56	 60 ○●	 46	 42 ●●●●●○	 30	 50 ○●	 58								
TABLE		 82					 70 ○●	 70 ●						 84						 78 ○●	 74 ●●●			
FLOOR		 82					 70 ○●	 70 ●						 84						 78 ○●				
WALL									 88 ○●												 92 ○○●●	 94		
OUTDOOR												 98								 100				





# PENDANTS

---

AVION | CARAVAGGIO | CARAVAGGIO MATT | CARAVAGGIO OPAL  
ORIENT | AEON ROCKET | CALABASH | MINGUS | LULLABY | PALLAS | CONCERT | BULB FICTION  
PHARAOH | JUICY | BRANCUSI | ATOMHEART

# AVION

DESIGN - ISKOS-BERLIN 2015

A childhood fascination of Zeppelin airships gliding with steady grace across the sky, has inspired Iskos-Berlin to create Avion. Despite its substantial size, the large oval pendant hovers playfully in the air, ready to change its direction to suit your desire. The pendant light is made of polyethylene and emits a soft, diffuse light that creates a cosy, natural atmosphere in the room. Avion can be arranged in a regular formation or as a dynamic pack. Similarly it can be suspended in one line to mark a passage through a building.

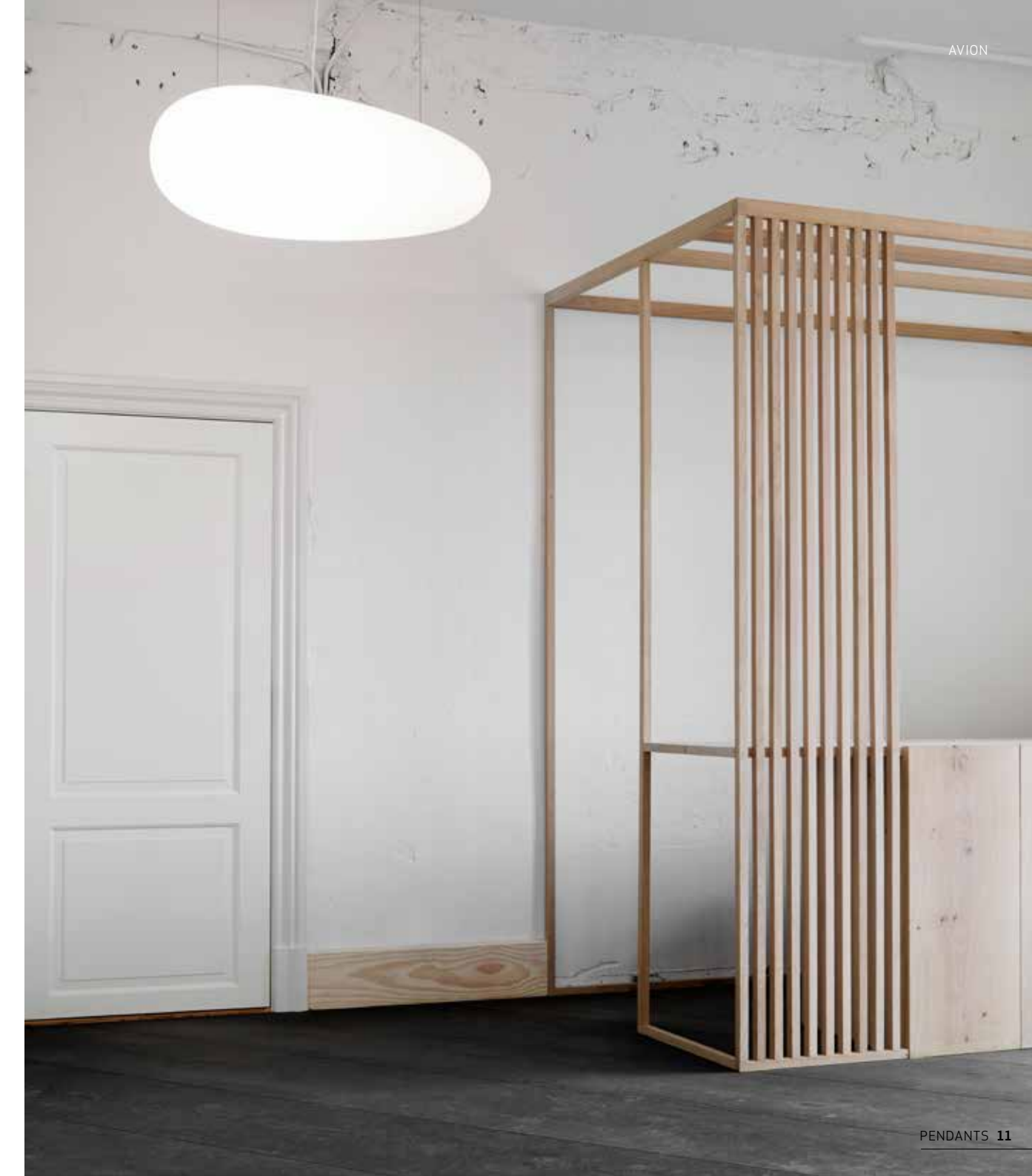





## FACTS

**MATERIAL** Polypropylene, ABS/PC.

### INSTALLATION

Suspension: White pvc cord 2 x 0,75mm<sup>2</sup>. Cord and wire length: 6 m. Canopy: White. Ceiling attachment: Chrome. Use an adjustable canopy to easily rotate and change the direction and the inclination of the pendants.

**CLASS** IP20, Class of insulation II.

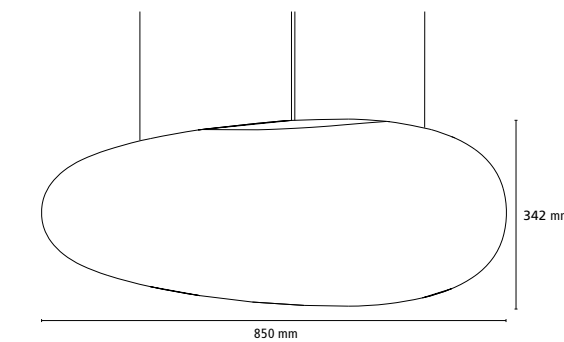

PRODUCT NAME	DESCRIPTION	LIGHT SOURCE	ENERGY LABEL	ELECTRONIC CONTROL GEAR
AVION Pendant - E27	Polypropylene, ABS/PC	E27 max 2x100W	A++, A+, A, B, C, D	
AVION Pendant - 2x42W	Polypropylene, ABS/PC	GX24q-4 2x42W	A	A1 BAT
AVION Pendant - DALI	Polypropylene, ABS/PC	GX24q-4 2x42W	A	A1

PRODUCT NAME	DESCRIPTION
AVION Adjustable Canopy	White lacquer



NEW

THIS IS THE NEW BLACK



## CARAVAGGIO MATT DESIGN - CECILIE MANZ 2011

The modest and unpretentious Caravaggio Matt model welcomes a new member of the family; the matt black pendant. The completely matt finish adds a rare depth and tangibility to the well-known and elegant Caravaggio design, imbuing it with a warm, cosy feel. The delicate blacks, whites and greys are finely balanced and interact neatly with each other if you choose to mix the pendants in your interior design solution. The discreet tones are timeless and suit more-or-less all settings.



CARAVAGGIO MATT P1 BLACK

PENDANTS 15

CARAVAGGIO MATT P1 BLACK



CARAVAGGIO MATT P4 GREY25



CARAVAGGIO MATT P2 BLACK





CARAVAGGIO MATT P2 GREY25 | P2 WHITE | P3 GREY45 | P1 GREY25

CARAVAGGIO MATT P1 WHITE | P2 GREY45 | P3 WHITE





CARAVAGGIO MATT P4 GREY25

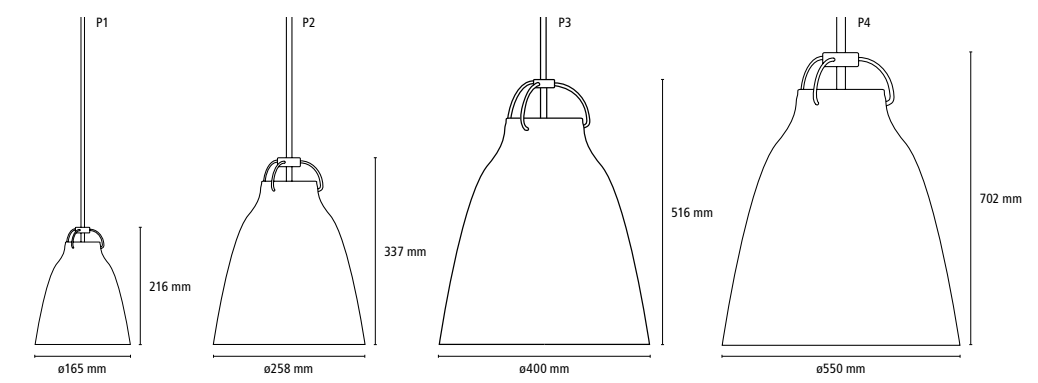

## FACTS

### COLOURS/SURFACE

White matt lacquer, white cord  
 Grey25 matt lacquer (light grey), light grey cord  
 Grey45 matt lacquer (darker, light grey), grey cord  
 Black matt lacquer, grey cord

**MATERIAL** Drawn steel/ aluminium.

### INSTALLATION

Suspension: White/light grey/grey textile cord 2 x 0,75 mm<sup>2</sup>.  
 Cord length: 3 m/6 m. Canopy: White.  
 Diffuser: Can be ordered separately for P3 and P4.

**CLASS** IP20, Insulation Class II.

Use a diffuser in opal translucent polycarbonate for Caravaggio P3 and P4 to prevent a direct line of sight to the light source when the pendant is hung high.

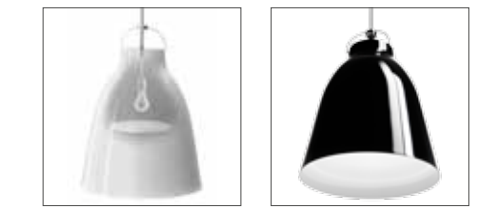

PRODUCT NAME	DESCRIPTION	LIGHT SOURCE	ENERGY LABEL
CARAVAGGIO MATT Pendant 1	Ø165 mm, matt lacquer	E27 max 42W	A++, A+, A, B, C, D
CARAVAGGIO MATT Pendant 2	Ø257 mm, matt lacquer	E27 max 100W	A++, A+, A, B, C, D
CARAVAGGIO MATT Pendant 3	Ø400 mm, matt lacquer	E27 max 100W	A++, A+, A, B, C, D
CARAVAGGIO MATT Pendant 4	Ø550 mm, matt lacquer	E27 max 150W	A++, A+, A, B, C, D

PRODUCT NAME	DESCRIPTION
CARAVAGGIO MATT Diffuser P3	Opal semi-translucent polycarbonate
CARAVAGGIO MATT Diffuser P4	Opal semi-translucent polycarbonate





CARAVAGGIO DESIGN - CECILIE MANZ 2005

## 10 YEARS ANNIVERSARY

---

The Caravaggio range of high-gloss pendants were launched in 2005 and instantly singled out as a design icon. The distinctive red cord and the polished surface clearly highlight one of the most striking pendant designs of the 2000s. With Caravaggio, designer Cecilie Manz elegantly combines a recognisable shape with a modern expression.





CARAVAGGIO P1 BLACK



CARAVAGGIO P3 WHITE

PENDANTS 25





CARAVAGGIO P1 BLACKBLACK



CARAVAGGIO P0 | P1 | P2 WHITE



## FACTS

### COLOURS/SURFACE

White high-gloss lacquer, grey cord  
 Black high-gloss lacquer, red cord  
 BlackBlack high-gloss lacquer, black cord, black suspension.

**MATERIAL** Drawn steel/ aluminium.

### INSTALLATION

Suspension: Grey/red/black textile cord 2 x 0,75 mm<sup>2</sup>.  
 Cord length: 3 m/6 m. Canopy: White and Black: White.  
 BlackBlack: Black.  
 Diffuser: Can be ordered separately for P3 and P4.

**CLASS** IP20, Insulation Class II.



Use a diffuser in opal translucent polycarbonate for Caravaggio P3 and P4 to prevent a direct line of sight to the light source when the pendant is hung high.

PRODUCT NAME	DESCRIPTION	LIGHT SOURCE	ENERGY LABEL	ELECTRONIC CONTROL GEAR
CARAVAGGIO Pendant 0	Ø110 mm, high-gloss lacquer	G9 max 33W	A+, A, D	
CARAVAGGIO Pendant 1	Ø165 mm, high-gloss lacquer	E27 max 42W	A++, A+, A, B, C, D	
CARAVAGGIO Pendant 2	Ø257 mm, high-gloss lacquer	E27 max 100W	A++, A+, A, B, C, D	
CARAVAGGIO Pendant 3	Ø400 mm, high-gloss lacquer	E27 max 100W	A++, A+, A, B, C, D	
CARAVAGGIO Pendant 4 - E27	Ø550 mm, high-gloss lacquer	E27 max 150W	A++, A+, A, B, C, D	
CARAVAGGIO Pendant 4 - 2x42W*	Ø550 mm, high-gloss lacquer	GX24q-4 2x42W	A	A1 BAT
CARAVAGGIO Pendant 4 - DALI*	Ø550 mm, high-gloss lacquer	GX24q-4 2x42W	A	A1

\*Available in white and black.

PRODUCT NAME	DESCRIPTION
CARAVAGGIO Diffuser P3	Opal semi-translucent polycarbonate
CARAVAGGIO Diffuser P4	Opal semi-translucent polycarbonate

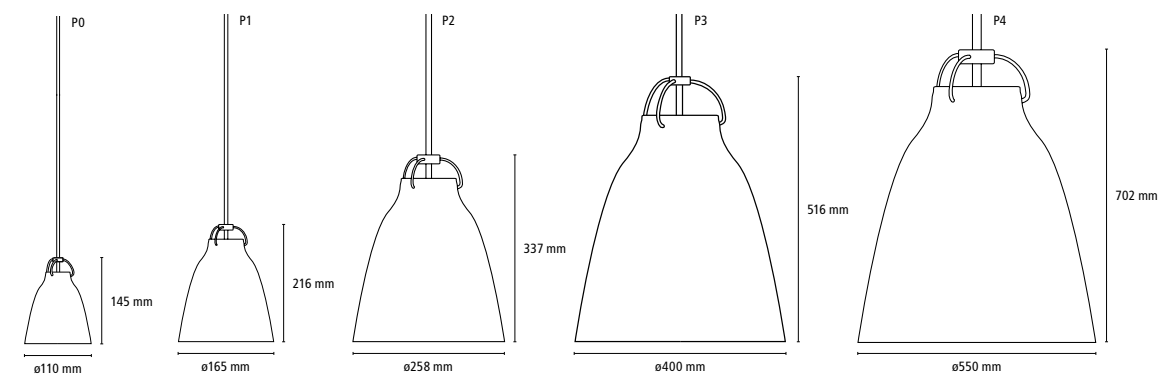



# CARAVAGGIO OPAL

DESIGN - CECILIE MANZ 2008

With Caravaggio Opal it is possible to combine the characteristic design with a completely different lighting effect. The Opal glass shade gives out a soft, dimmed light which is particularly suited for rooms where a more evocative lighting is required. The lamp is suspended by the three well-known shackles which here form a raw and masculine contrast to the feminine opal hand-blown glass.

## FACTS

**SURFACE** Hand-blown opal glass in three layers, matt chrome.

**INSTALLATION** Suspension: Silver textile cord 2 x 0,75 mm<sup>2</sup>.  
Cord length: 3 m. Canopy: White.

**CLASS** IP20, Insulation Class II.

PRODUCT NAME	DESCRIPTION	LIGHT SOURCE	ENERGY LABEL
CARAVAGGIO OPAL Pendant 0	Ø110 mm, hand-blown opal glass	G9 max 33W	A+, A, D
CARAVAGGIO OPAL Pendant 1	Ø165 mm, hand-blown opal glass	E27 max 42W	A++, A+, A, B, C, D
CARAVAGGIO OPAL Pendant 2	Ø257 mm, hand-blown opal glass	E27 max 100W	A++, A+, A, B, C, D
CARAVAGGIO OPAL Pendant 3	Ø400 mm, hand-blown opal glass	E27 max 100W	A++, A+, A, B, C, D

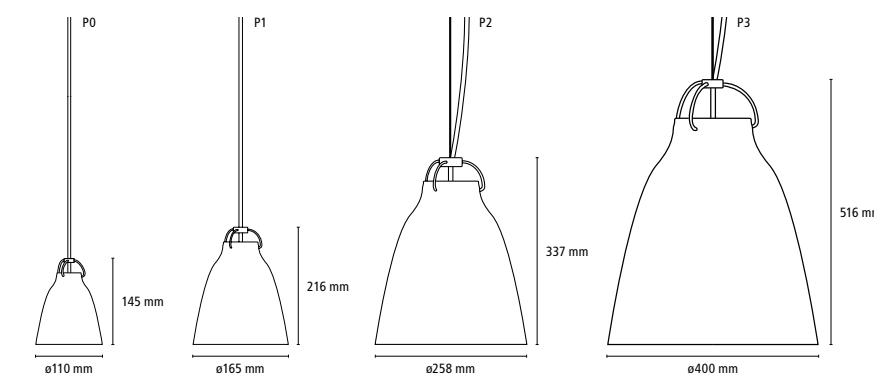



## ORIENT DESIGN - JO HAMMERBORG 1963

The Orient pendant is a flawless light design with good luminous efficacy and made from the finest quality materials. The organic mode of expression beautifully connects the deep, vibrant copper glow and the rosewood top. The lamp has 21/24 narrow, vertical slots at the top of the genuine copper shade allowing light to filter through. The pendant ensures a soft, pleasant light without any glare.





ORIENT P2



ORIENT P1

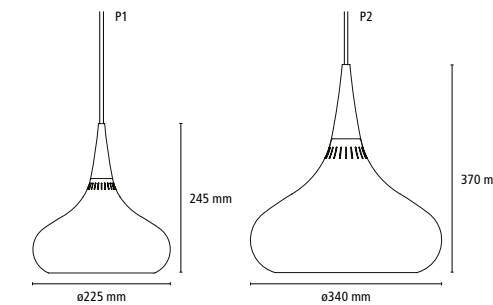

## FACTS

**SURFACE** Polished copper with clear lacquer.

**MATERIAL** Genuine copper, rosewood.

**INSTALLATION** Suspension: Black closely woven textile cord 2 x 0,75 mm<sup>2</sup>. Cord length: 3 m/6 m. Canopy: Black.

**CLASS** IP20, Insulation Class II.

PRODUCT NAME	DESCRIPTION	LIGHT SOURCE	ENERGY LABEL
ORIENT Pendant 1	Ø225 mm, copper and rosewood	E27 max 60W	A++, A+, A, B, C, D
ORIENT Pendant 2	Ø340 mm, copper and rosewood	E27 max 75W	A++, A+, A, B, C, D



# AEON ROCKET

DESIGN - MORTEN VOSS 2014

---

Aeon Rocket is the first pendant in history to take full advantage of the luminous qualities of metal and polypropylene simultaneously in a single pendant design. The lamp strikes a fine balance between a simple metal upper shade and a gauzy lower shade. However, the impression of lightness is created by hours and hours of meticulous manual work. 8 light bands made of recyclable polypropylene are carefully woven together into 100 and 98 round openings respectively, allowing the light to stream through unhindered.





## FACTS

### COLOURS/SURFACE

Aeon-Black semi matt lacquer, dark grey cord  
Aeon-Grey semi matt lacquer, light grey cord.

**MATERIAL** Drawn steel/aluminium, polypropylene, polycarbonate.

### INSTALLATION

Suspension: Dark grey/Light grey textile cord 2 x 0,75 mm<sup>2</sup>.  
Cord length: 3 m/6 m. Canopy: White. Delivered incl. matching bulb shield to prevent the light source from being visible.

**CLASS** IP20, Insulation Class II.

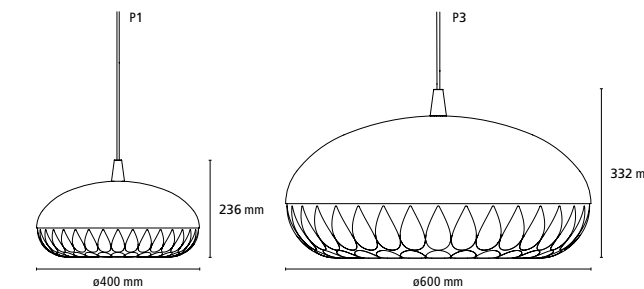

PRODUCT NAME	DESCRIPTION	LIGHT SOURCE	ENERGY LABEL
AEON ROCKET Pendant 1	Ø400 mm, semi matt lacquer	E27 max 77W	A++, A+, A, B, C, D
AEON ROCKET Pendant 3	Ø600 mm, semi matt lacquer	E27 max 150W	A++, A+, A, B, C, D





## CALABASH DESIGN – KOMPLOT DESIGN 2011

Calabash is authentic craftsmanship from the core to the surface. The organic design idiom and the specially chromed and slightly changeable surface provide Calabash with a unique expression. Every pendant goes through a comprehensive 4-step lacquering process, which is exclusively carried out by hand. The three pendant sizes present the same easily recognisable shape, although without being identical.



## FACTS

**COLOURS/SURFACE** Black, silver, gold and red, high-gloss chrome lacquer.

**MATERIAL** Drawn aluminium. Installation Suspension: Black closely woven textile cord 2 x 0,75 mm<sup>2</sup>. Cord length: 3 m/6 m. Canopy: Black.

**CLASS** IP20, Insulation Class II.

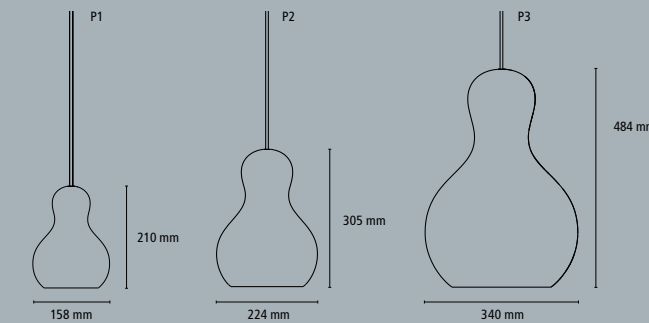
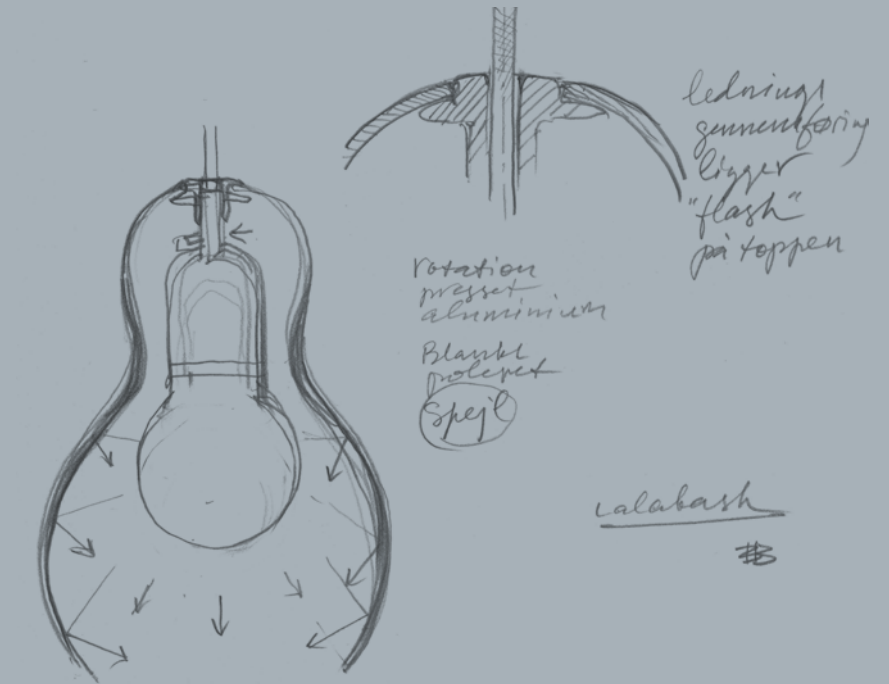

PRODUCT NAME	DESCRIPTION	LIGHT SOURCE	ENERGY LABEL
CALABASH Pendant 1	Ø158 mm, high-gloss chrome lacquer	E27 max 30W	A++, A+, A, B, C, D
CALABASH Pendant 2	Ø224 mm, high-gloss chrome lacquer	E27 max 42W	A++, A+, A, B, C, D
CALABASH Pendant 3	Ø340 mm, high-gloss chrome lacquer	E27 max 100W	A++, A+, A, B, C, D





# MINGUS

DESIGNED - CECILIE MANZ 2012

Mingus is organic even if it originates in four straight facets. The lamp's top is flat and fitted with an acrylic fixture that allows light to seep out. The Mingus pendant is available in six matt nuances. In addition to pure white, there are five other tones: blue-black, neutral grey, dusty moss green, a light green tone resembling celadon glazen and an off-white nuance a bit reminiscent of limestone. The tones change in different light and take on the colour of their surroundings.







MINGUS P1 DUSTY LIMESTONE



MINGUS P1 LIGHT CELADON



MINGUS P1 NEARLY BLACK



MINGUS P1 PALE MOSS



MINGUS P1 VERY GREY



MINGUS P1 WHITE

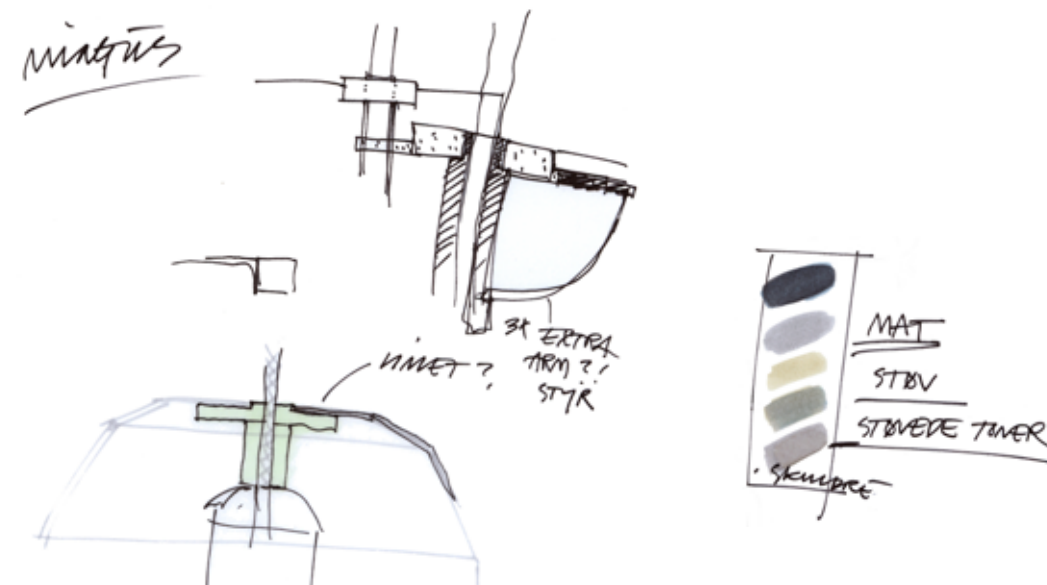

## FACTS

### COLOURS/SURFACE

Dusty Limestone, Very Grey, Pale Moss, Light Celadon, Nearly Black and White, matt lacquer.

### MATERIAL

Aluminium.

### INSTALLATION

Suspension: White: White textile cord 2 x 0,75 mm<sup>2</sup>.  
Other colours: Light grey textile cord 2 x 0,75 mm<sup>2</sup>. Cord length: 3 m/6 m.  
Canopy: White.

CLASS IP20, Insulation Class II.

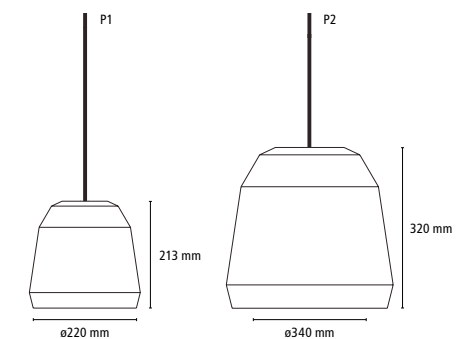

PRODUCT NAME	DESCRIPTION	LIGHT SOURCE	ENERGY LABEL
MINGUS Pendant 1	Ø220 mm, semi-matt lacquer	E27 max 46W	A++, A+, A, B, C, D
MINGUS Pendant 2	Ø340 mm, semi-matt lacquer	E27 max 70W	A++, A+, A, B, C, D

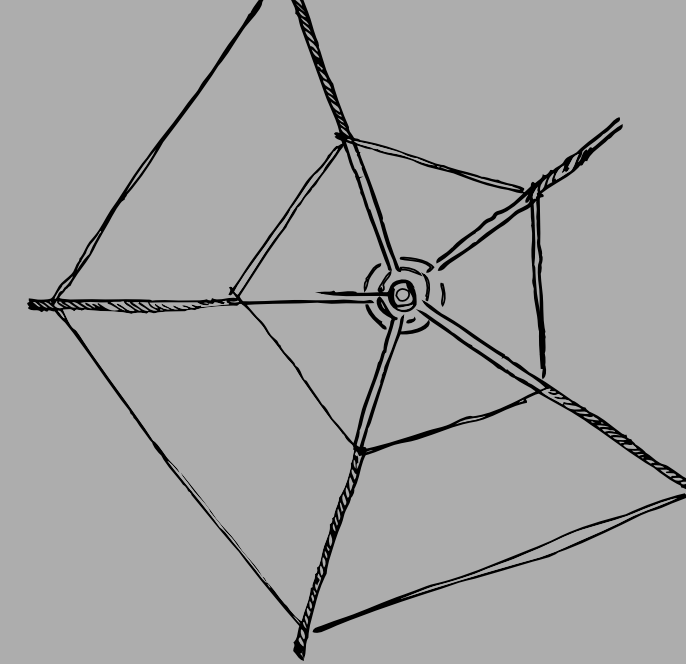

# LULLABY

DESIGN - MONICA FÖRSTER 2014

---

The Lullaby pendants are made from stone paper with ash lamellae. The stone paper is fashioned into pentagonal, yet slightly organic-looking shapes using five slender ash lamellae. The ash gives the soft stone paper stability, which translates as a lamp with both shape and character. Stone paper is made from crushed limestone, which is robust and water-repellent, yet soft and sensory. In addition, stone paper has outstanding luminous qualities, which enable the Lullaby to emit a soft, muted light.



LULLABY P2



LULLABY P1 | P2 | P3



## FACTS

**MATERIAL** Stone paper, ash.

**INSTALLATION** Suspension: White textile cord  
2 x 0,75 mm<sup>2</sup>. Cord length: 3 m/ 6 m. Canopy: White.

**CLASS** IP20, Insulation Class II.

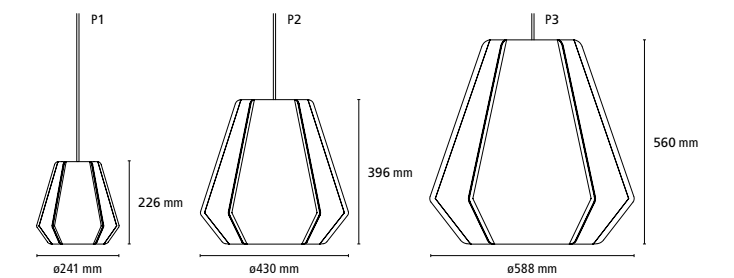

PRODUCT NAME	DESCRIPTION	LIGHT SOURCE	ENERGY LABEL
LULLABY Pendant 1	Ø241 mm, stone paper, ash	E27 max 46W	A++, A+, A, B, C, D
LULLABY Pendant 2	Ø430 mm, stone paper, ash	E27 max 100W	A++, A+, A, B, C, D
LULLABY Pendant 3	Ø588 mm, stone paper, ash	E27 max 100W	A++, A+, A, B, C, D





# PALLAS

DESIGN - FORMFJORD 2012

---

Pallas is a contemporary large room pendant with a unique character inspired by historic chandeliers. The vertical laser-cut slits in the shade creates openings for the light and creates a sophisticated interplay of light and shadow. With its substantial size, Pallas is made to illuminate grand architectural projects like lobbies, airports, theaters and museums. Pallas is, manufactured in Denmark, and delivered four weeks after order





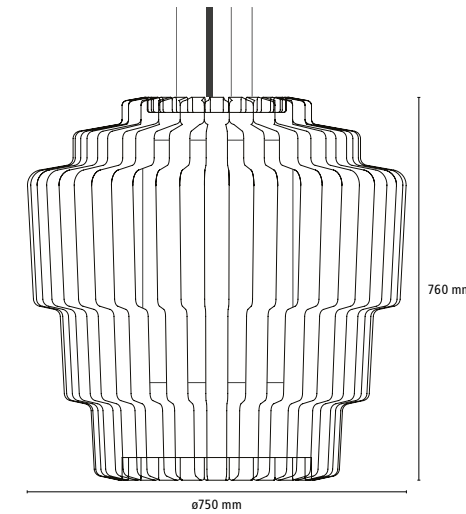
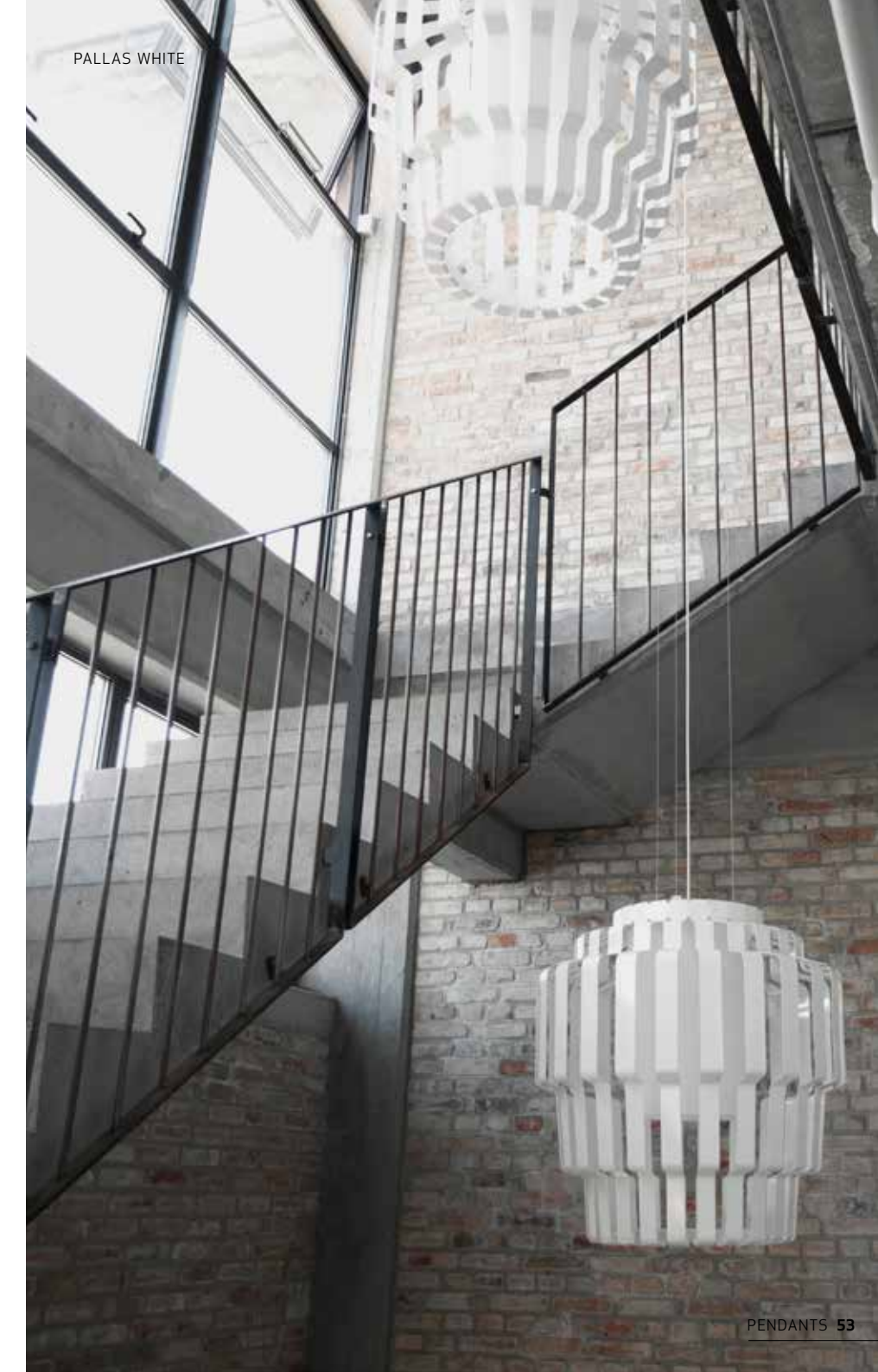

## FACTS

**SURFACE** White or black high-gloss lacquer.

**MATERIAL** Steel, acid treated opal glass.

**INSTALLATION** Suspension: White or black pvc cord  
2 x 0,75 mm<sup>2</sup>. Cord and wire length: 6 m.  
Canopy: White or black.

**CLASS** IP 20, Insulation Class II.

PRODUCT NAME	DESCRIPTION	LIGHT SOURCE	ENERGY LABEL
PALLAS Pendant	Ø750 mm, high-gloss lacquer	E27 max 200W	A++, A+, A, B, C, D





KOMPLOT DESIGN  
BORIS BERLIN  
POUL CHRISTIANSEN  
CALABASH



CECILIE MANZ  
BRANCUSI  
CARAVAGGIO  
CARAVAGGIO MATT  
CARAVAGGIO OPAL  
CARAVAGGIO WALL  
MINGUS  
MONDRIAN



ISKOS - BERLIN  
ALEKSEJ ISKOS  
BORIS BERLIN  
AVION

KNUD HOLSCHER  
PRIMULA



HULGER  
MICHAEL-GEORGE HEMUS  
NICOLAS ROOPE  
PHARAOH



JØRN UTZON  
CONCERT

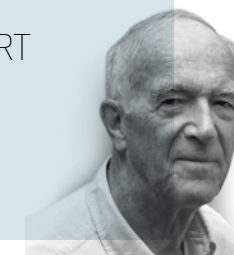

# OUR DESIGNERS



MONICA FÖRSTER  
LULLABY



HIDENORI KUGE  
TAKERU

HANS SANDGREN  
JAKOBSEN  
RADON



FORMFJORD  
SÖNKE HOFF  
FABIAN BAUMANN  
PALLAS



JO HAMMERBORG  
ORIENT



GAMFRATESI  
VOLUME



KIBISI  
LARS HOLME LARSEN  
BJARKE INGELS  
JENS MARTIN SKIBSTED  
BULB FICTION



SALTO & SIGSGAARD  
KASPER SALTO  
THOMAS SIGSGAARD  
JUICY



MORTEN VOSS  
AEON ROCKET  
ATOMHEART



HENNING  
LARSEN  
HL





CONCERT P3

# CONCERT

DESIGN - JØRN UTZON 2005

Concert gives a pleasant, non-glaring light without compromising the strength of illumination. The chosen shade configuration is visually characteristic of Jørn Utzon and reminds us of his greatest work. Concert is built up of four shades and a parabola of drawn steel, which is mounted on a glass suspension. The suspension unit sends out a pleasant, even light between the shades. The bottom shade casts light downward to the parabola, which then diffuses it.

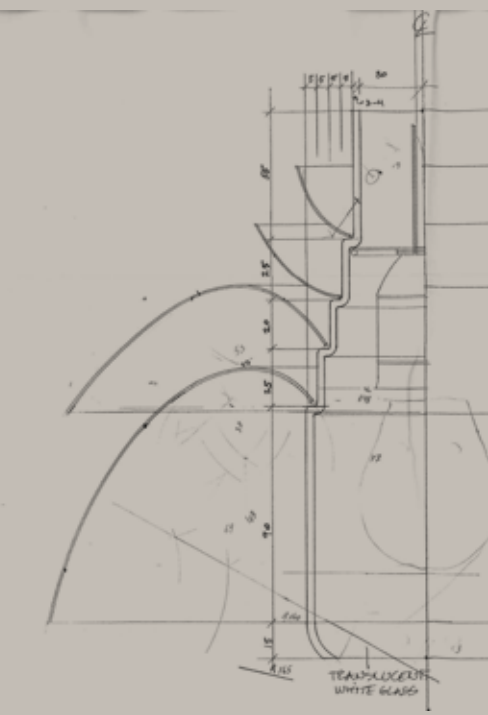

## FACTS

**SURFACE** White lacquer.

**MATERIAL** Shade: Drawn steel.  
Suspension: Acid frosted glass.

**INSTALLATION** Suspension: White textile cord  
2x0,75mm<sup>2</sup>. Cord length P1: 3 m. Cord and wire  
length P3: 6 m. Canopy: White.

**CLASS** IP 20, Insulation Class II.

PRODUCT NAME	DESCRIPTION	LIGHT SOURCE	ENERGY LABEL
CONCERT Pendant 1	Ø320 mm, white lacquer	E27 max 75W	A++, A+, A, B, C, D
CONCERT Pendant 3	Ø550 mm, white lacquer	E27 max 150W	A++, A+, A, B, C, D

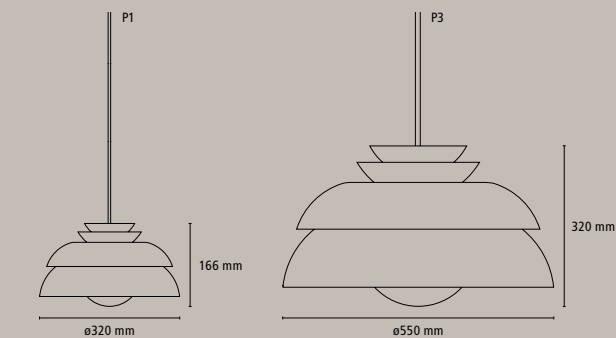





# PHARAOH

DESIGNED - HULGER 2013

Pharaoh is a unique pendant light created to enhance the expression of the Plumen light source. When the lamp is switched off, the shade appears to be mirror-like, reflective and robust. And yet, the moment the lamp is switched on, the shade takes on a metallic transparency, thereby making the light source visible. The transformation between illuminated and non-illuminated is truly remarkable. Pharaoh comes with a Plumen 001 light source.

## FACTS

**SURFACE** Mirror coating.

**MATERIAL** Injection-moulded ABS plastic and aluminium.

**INSTALLATION** Suspension: Black closely woven textile cord 2 x 0,75 mm<sup>2</sup>. Cord length: 3m. Canopy: Black.

**CLASS** IP20, Insulation Class II.

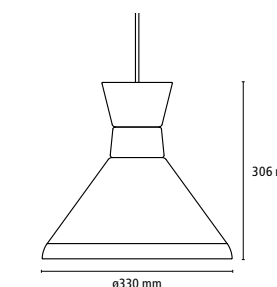

PRODUCT NAME	DESCRIPTION	LIGHT SOURCE	ENERGY LABEL
PHARAOH Pendant	Ø330 mm, semi-transparent mirror coating	E27 max 46W	A++, A+, A, B, C, D

\* Light source (E27 Plumen 001 11W) included

A type included

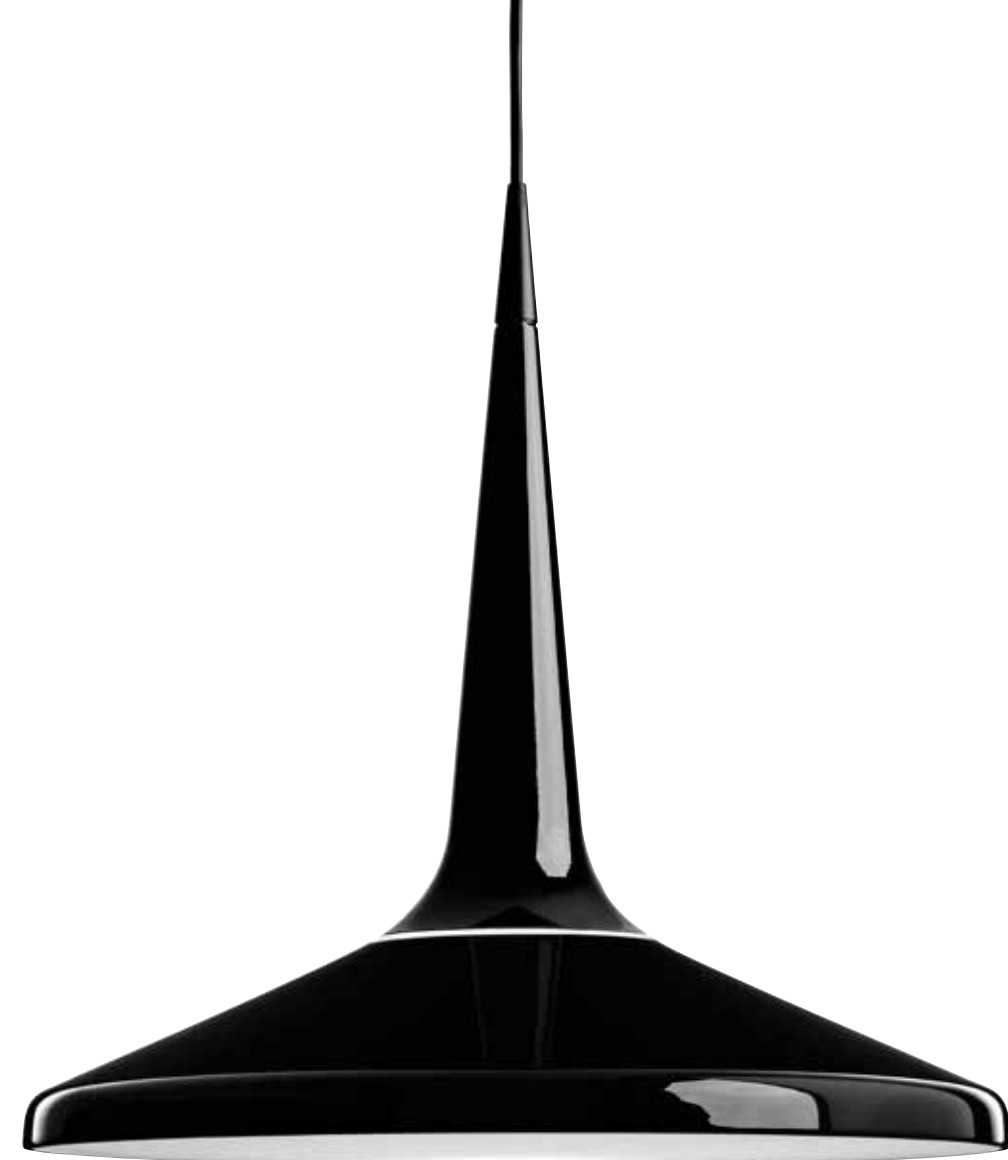

JUICY DESIGN - SALTO & SIGSGAARD 2011



JUICY BLACK



The Juicy pendant is logical, simple and functional. The various parts of the lamp; the wire, cone and shade come together seamlessly, which makes the pendant seem like an organic whole. Towards the bottom, Juicy is finished off with a honeycomb-filter, which effectively concentrates the light while preventing dazzling at the same time. Juicy's glossy surface is visually broken by a shining ring, which marks where the lamp is to be separated for change of light source.

## FACTS

### COLOURS/SURFACE

Black or white, high-gloss lacquer.

**MATERIAL** Drawn aluminium, die-cast zinc alloy, polycarbonate honeycomb diffuser.

**INSTALLATION** Suspension: Black or white cord 2 x 0,75 mm<sup>2</sup>. Cord length: 6 m. Canopy: Black or white.

**CLASS** IP20, Insulation Class II.

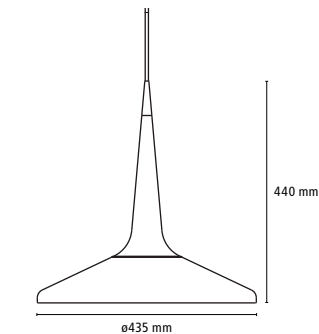

PRODUCT NAME	DESCRIPTION	LIGHT SOURCE	ENERGY LABEL
JUICY Pendant	Ø435 mm, high-gloss lacquer	E27 max 30W	A++, A+, A, B, C, D



# BULB FICTION

DESIGN - KIBISI 2012

Bulb Fiction is close to the classic incandescent bulb, but the shape has been upscaled and designed as a whole unit, uniting socket and bulb into one iconic shape. The same applies to the cord, which has been given extra volume using a thick white silicone cover. Bulb Fiction consists of a hand-blown acid treated opal glass shade and an aluminium suspension with a soft, organic shape.

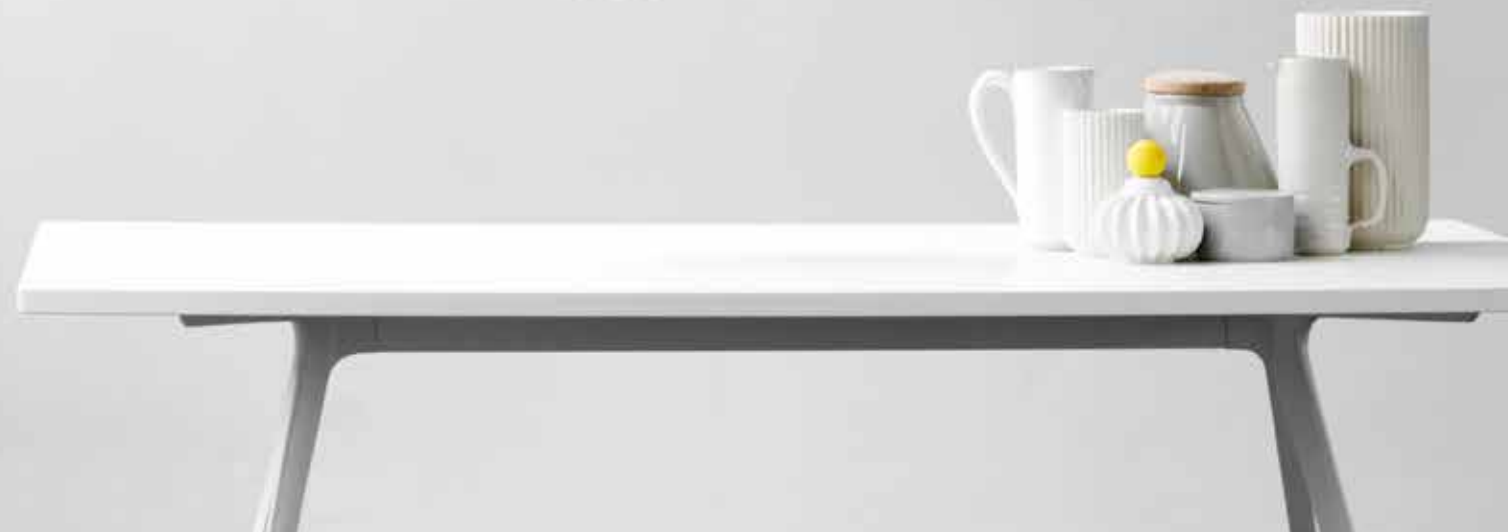

## FACTS

**SURFACE** White lacquer.

**MATERIAL** Shade: Hand-blown acid treated opal glass. Suspension: Aluminium.

**INSTALLATION** Suspension: Pvc cord 2 x 0,75 mm<sup>2</sup> with 0,7 mm thick white silicone cover. Cord length: 3 m/6 m. Canopy: White.

**CLASS** IP 20, Insulation Class II.  
Min. distance to flammable material: 30 cm.

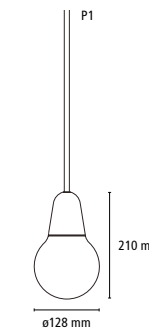

PRODUCT NAME	DESCRIPTION	LIGHT SOURCE	ENERGY LABEL
BULB FICTION Pendant	Ø128 mm, white lacquer, opal glass	E27 max 42W	A++, A+, A, B, C, D





# BRANCUSI

DESIGN - CECILIE MANZ 2008

The Brancusi pendant meets a wide range of technical challenges in a pure, relaxed and rounded form. Brancusi is designed to illuminate rooms with a high ceiling using a large, integrated aluminium reflector. The silk-printed white circles on the glass soften the light emitted, helping to create the unique impression.

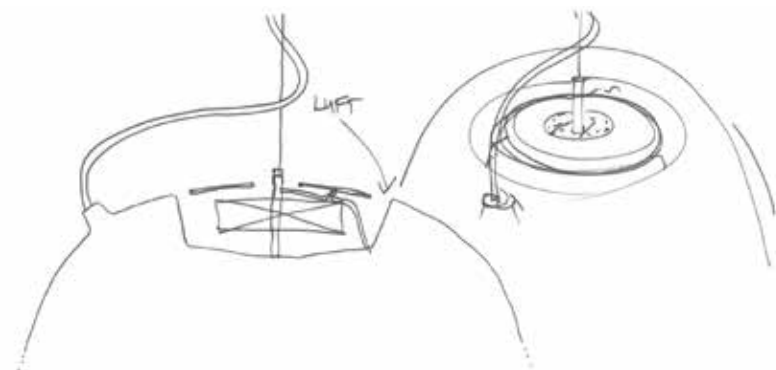

## FACTS

**SURFACE** White polycarbonate, silk-printed glass.

**MATERIAL** Shade: Polycarbonate. Reflector: Aluminium. Bottom plate: Plexiglass.

**INSTALLATION** Suspension: White pvc cord 2 x 0,75 mm<sup>2</sup>. Cord and wire length: 6 m. Canopy: White. Diffuser: Can be ordered separately.

**CLASS** IP20, Insulation Class II.

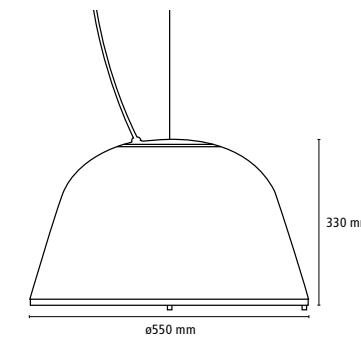

PRODUCT NAME	DESCRIPTION	LIGHT SOURCE	ENERGY LABEL	ELECTRONIC CONTROL GEAR
BRANCUSI Pendant - E27	Ø550 mm, white polycarbonate, silk-printed glass	E27 max 200W	A++, A+, A, B, C, D	
BRANCUSI Pendant - G12	Ø550 mm, white polycarbonate, silk-printed glass	G12 70W	A+	A2

PRODUCT NAME	DESCRIPTION
BRANCUSI Diffuser	Opal semi-translucent PETG





# ATOMHEART

DESIGN - MORTEN VOSS 2008

Light and shade are equal elements in the design universe, a balance which led Morten Voss to create the Atomheart pendants. When the lamp is lit, the design of the shade forms contrasts which enhance the impression created by the shape of the glass, where no two angles are alike, but change all the way round. Hence, the lamp appears as a complex and distinctive light source with a life of its own.

## FACTS

**SURFACE** Hand-blown acid treated opal glass in three layers, white high-gloss lacquer.

**INSTALLATION** Suspension: White textile cord 2 x 0,75 mm<sup>2</sup>. Cord and wire length: 3 m. Canopy: White.

**CLASS** IP20, Insulation Class II.

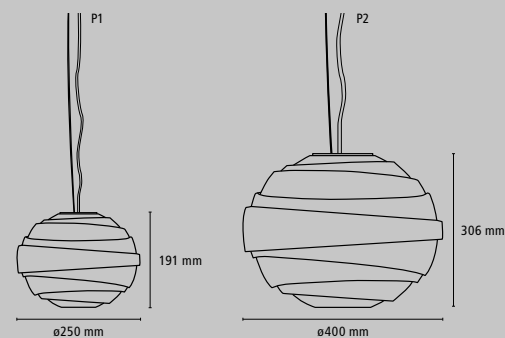

PRODUCT NAME	DESCRIPTION	LIGHT SOURCE	ENERGY LABEL
ATOMHEART Pendant 1	Ø250 mm, hand-blown acid treated opal glass, white high-gloss lacquer	E14 max 40W	A++, A+, A, B, C, D
ATOMHEART Pendant 2	Ø400 mm, hand-blown acid treated opal glass, white high-gloss lacquer	E27 max 100W	A++, A+, A, B, C, D



# TABLE & FLOOR LAMPS

---

CARAVAGGIO | VOLUME | RADON | ATOMHEART | MONDRIAN







NOW AVAILABLE IN MATT GREY LACQUER



# CARAVAGGIO

DESIGN - CECILIE MANZ 2008

Both the Caravaggio table lamp and floor lamp are made of metal with a lacquer finish. A flexible tube, which is hidden by the shade, has been mounted on the standard which makes it possible to tilt the shade, and with it the light cone, up to 40 degrees. This function makes the lamps more flexible and functional as light sources. The charming little string close to the light functions as a switch. The Caravaggio table lamp is available in two versions - either on a base, or for plugging in.



## FACTS

### COLOURS/SURFACE

White high-gloss and matt lacquer (with grey cord)  
 Black high-gloss and matt lacquer (with red cord)  
 Grey matt lacquer (with grey cord).

**MATERIAL** Shade: Drawn aluminium. Base: Steel.

**INSTALLATION** Black or grey textile cord with plug.

Cord length: Floor: 1,75 m. Table: 2,5 m.

Switch: Grey or red textile string by the shade.

**CLASS** IP20, Insulation Class II.

PRODUCT NAME	DESCRIPTION	LIGHT SOURCE	ENERGY LABEL
CARAVAGGIO Table	High-gloss/matt lacquer	E27 max 46W	A++, A+, A, B, C, D
CARAVAGGIO Table plug-in	High-gloss/matt lacquer	E27 max 46W	A++, A+, A, B, C, D
CARAVAGGIO Floor	High-gloss/matt lacquer	E27 max 150W	A++, A+, A, B, C, D

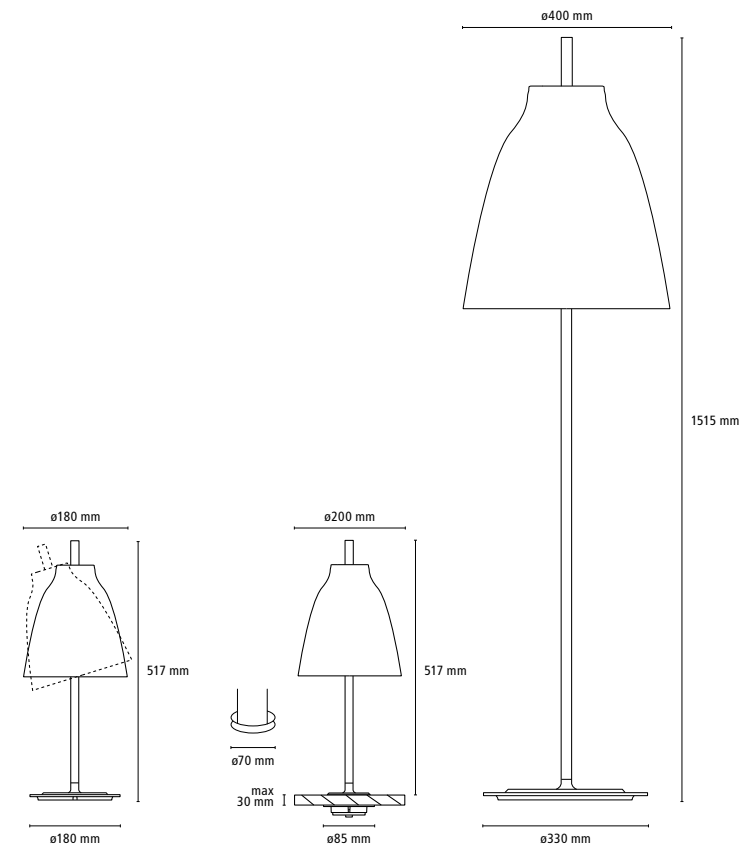





# VOLUME

DESIGN - GAMFRATESI 2014

---

Inspired by the buttons on an original stereo amplifier from the 1980s, GamFratesi has created Volume.

Allow yourself to be fascinated by a seemingly forgotten gesture, where one via a mechanical rotation of a button gains an intuitive understanding of the function - to increase or decrease the volume. The lampshade invites one to change the intensity of the light by a simple rotation of the hand on the shade. The lamp emits a pleasant light 360 degrees around and out through the opening at the top of the lamp. The LEDs burn for 50,000 hours on average, without any maintenance being required.

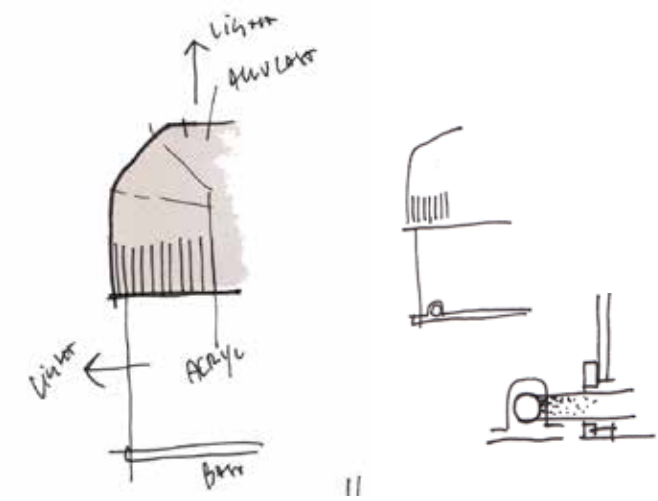

## FACTS

### COLOURS

Blackbird, Evergreen or Fade-to-grey, matt lacquer.

**MATERIAL** Die-cast aluminium, acrylic.

LED 3 x Osram Oslon Square 2700K 1W (350mA).

**INSTALLATION** White/black pvc cord with plug.  
Cord length: 1,5m. Switch: On shade. Wattage: 3,4W.  
Efficiency: 96 lm / W. Colour rendering: >90.  
Colour temperature: 2700 K. Lifetime: 50,000 hours.  
No-load mode: 0W.

**CLASS** IP20, Insulation Class II.

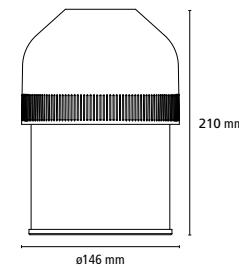

PRODUCT NAME	DESCRIPTION	LIGHT SOURCE	ENERGY LABEL
VOLUME LED Table	Matt lacquer, acrylic	3 x Osram Oslon Square 1W (350mA)	LED, A+





# RADON

DESIGN - HANS SANDGREN JAKOBSEN 2005

---

The fundamental geometric forms - the circle and the triangle - are key elements in the design of the Radon series. The light from Radon is direct and adjustable. The shade is multi-directional and furnished with an asymmetrical reflector, ensuring that light spreads out precisely to the surface where it is needed. The switch is placed at the top of the lamp, while the cord leads discreetly out of the back leg to help preserve the lamp's clean lines.





RADON BLACK FLOOR | TABLE

## FACTS

### COLOURS/SURFACE

Black: Matt black lacquer, matt chrome.

Nigra: Matt black lacquer.

**MATERIAL** Shade: Sandblasted aluminium laquered.

Base: Turned brass and steel bars/round steel with matt chrome coating/black lacquer.

**INSTALLATION** Black pvc cord.

Cord length: Floor: 2,45 m. Table: 2 m. Switch: On shade.

**CLASS** IP 20, Insulation Class II.

PRODUCT NAME	DESCRIPTION	LIGHT SOURCE	ENERGY LABEL
RADON Table	Matt lacquer / matt lacquer and chrome	E14 max 60W	A++, A+, A, B, C, D
RADON Floor	Matt lacquer / matt lacquer and chrome	E14 max 25W	A++, A+, A, B, C, D

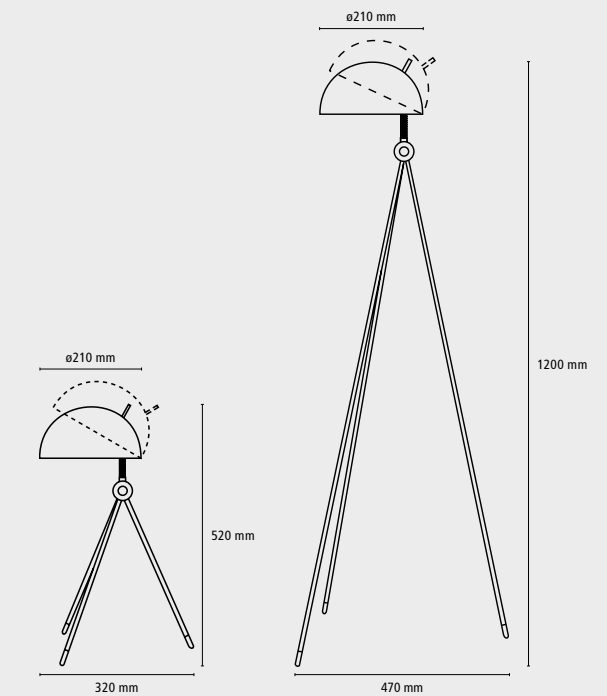



# ATOMHEART

DESIGN - MORTEN VOSS 2008

Light and shade are equal elements in the design universe, a balance which led Morten Voss to create the Atomheart lamps. Atomheart provides a diffuse light. When the lamp is lit, the design of the shade forms contrasts which enhance the impression created by the shape of the glass, where no two angles are alike, but instead change all the way round. Both lamps have an electronic dimmer, which allows a regulation of light intensity.



## FACTS

**SURFACE** Opal glass, white high-gloss lacquer.  
**MATERIAL** Hand-blown acid frosted opal glass in three layers. Base: Zinc-alloy.  
**INSTALLATION** White pvc cord with plug. Cord length: Floor: 1,7 m. Table: 2,6 m. Switch: On cord. Dimmable: Yes.  
**CLASS** IP20, Insulation Class II.

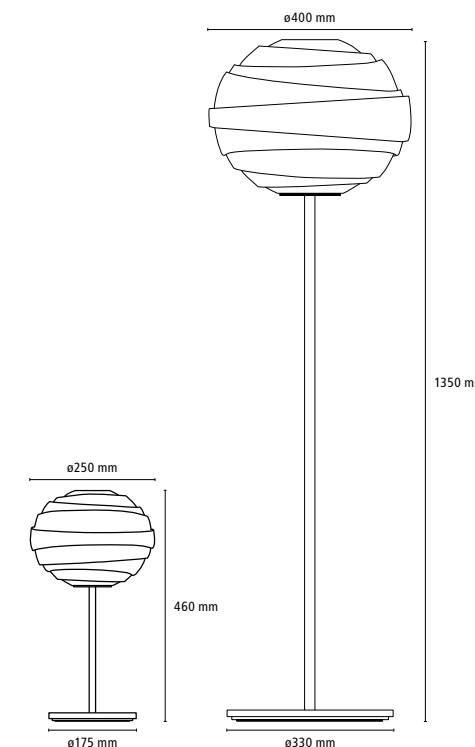

PRODUCT NAME	DESCRIPTION	LIGHT SOURCE	ENERGY LABEL
ATOMHEART Table	White high-gloss lacquer, hand-blown opal glass, w/dimmer	E14 max 40W	A++, A+, A, B, C, D
ATOMHEART Floor	White high-gloss lacquer, hand-blown opal glass, w/dimmer	E27 max 100W	A++, A+, A, B, C, D





# MONDRIAN

DESIGN - CECILIE MANZ 2005

Minimalist design was the driving force for Cecilie Manz in her development of Mondrian. The lamps appears as a line in the air, and break the conventional assumption of how a lamp should look. The translucent ring in acrylic lights up when the lamp is on, and indicates how to adjust the light. Mondrian's light can be directed 180 degrees horizontally and 335 degrees vertically.

## FACTS

**SURFACE** White high-gloss lacquer.

**MATERIAL** Base: Round steel and steel tubes.  
Lamp head: Moulded steel.

**INSTALLATION** Grey pvc cord with plug.  
Cord length: Floor 3 m. Table: 2,8 m. Switch: On cord.  
Transformer: 12V on the cord.

**CLASS** IP20, Insulation Class II.

PRODUCT NAME	DESCRIPTION	LIGHT SOURCE	ENERGY LABEL
MONDRIAN Table	White lacquer, acrylic	G4 max 20W	C
MONDRIAN Floor	White lacquer, acrylic	G4 max 20W	C

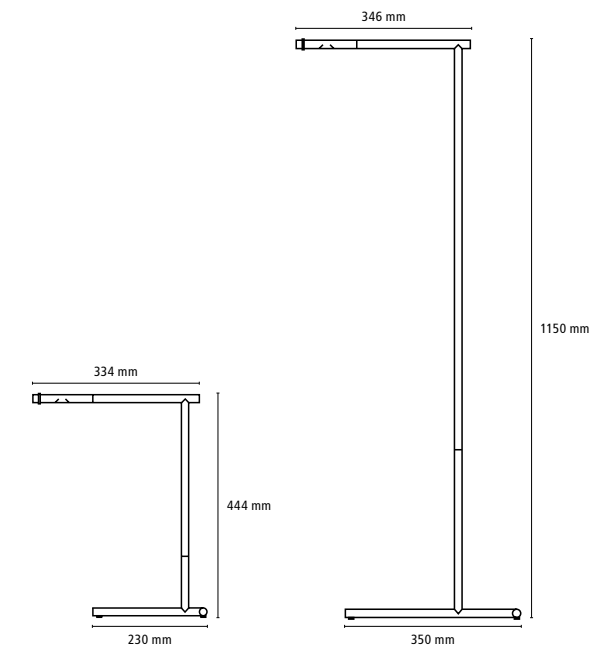





# WALL LAMPS

---

CARAVAGGIO | RADON | TAKERU

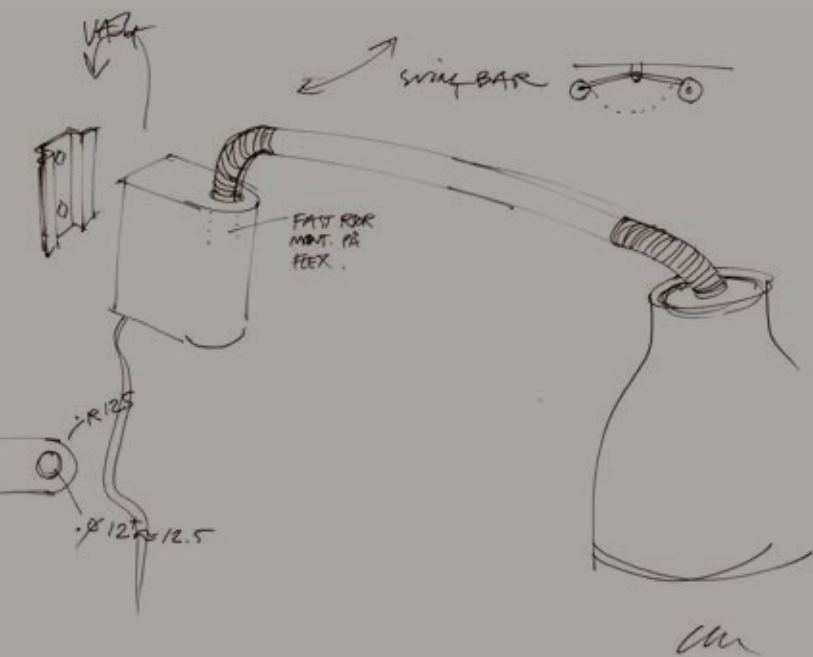

# CARAVAGGIO

DESIGN - CECILIE MANZ 2013

Based on the well-known Caravaggio shape, Cecilie Manz has created a wall lamp that is precise, refined and, above all, functional. The classic shade is installed on a flexible tube, which makes it possible to tilt the shade and thereby direct the light. The wall bracket means the lamp can be rotated 180 degrees, which – together with the flextube – makes the lamp very flexible. The switch is positioned discreetly at the bottom of the wall bracket to ensure easy access.





CARAVAGGIO WALL WHITE



CARAVAGGIO WALL BLACK



CARAVAGGIO WALL BLACK



## FACTS

### COLOURS/SURFACE

Black or white semi matt lacquer.

**MATERIAL** Drawn steel and die-cast zinc alloy.

**INSTALLATION** Black or white pvc cord with plug.  
Cord length: 1,5m. Switch: On wall bracket. Delivered  
incl. two fittings; one for direct installation on power  
outlet and one for installation with visible wiring.

**CLASS** IP20, Insulation Class II.

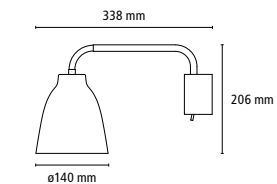

PRODUCT NAME	DESCRIPTION	LIGHT SOURCE	ENERGY LABEL
CARAVAGGIO WALL	Matt lacquer	E27 max 46W	A++, A+, A, B, C, D



RADON ALBA WALL

# RADON

DESIGN - HANS SANDGREN JAKOBSEN 2005

The light from Radon is direct and adjustable. The shade is furnished with an asymmetrical reflector, ensuring that light spreads out precisely to the surface where it is needed. The switch is placed at the top of the lamp for easy handling. Radon wall offers both an indirect and a direct light as the semi-spherical lampshade can be oriented from 0 to 90°.



## FACTS

### COLOURS/SURFACE

Black: Matt chrome and black lacquer  
 Nigra: Matt black lacquer  
 White: Matt chrome and white lacquer  
 Alba: Matt white lacquer.

**MATERIAL** Shade: Sandblasted aluminium laquered.  
 Base: Moulded steel and steel bars covered in matt chrome.

**INSTALLATION** Black or white pvc cord with plug.  
 Cord length: 3,3 m. Switch: On shade.

**CLASS** IP20, Insulation Class II.

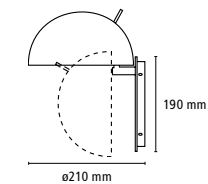

PRODUCT NAME	DESCRIPTION	LIGHT SOURCE	ENERGY LABEL
RADON Wall	Matt lacquer / matt lacquer and chrome	E14 max 60W	A++, A+, A, B, C, D

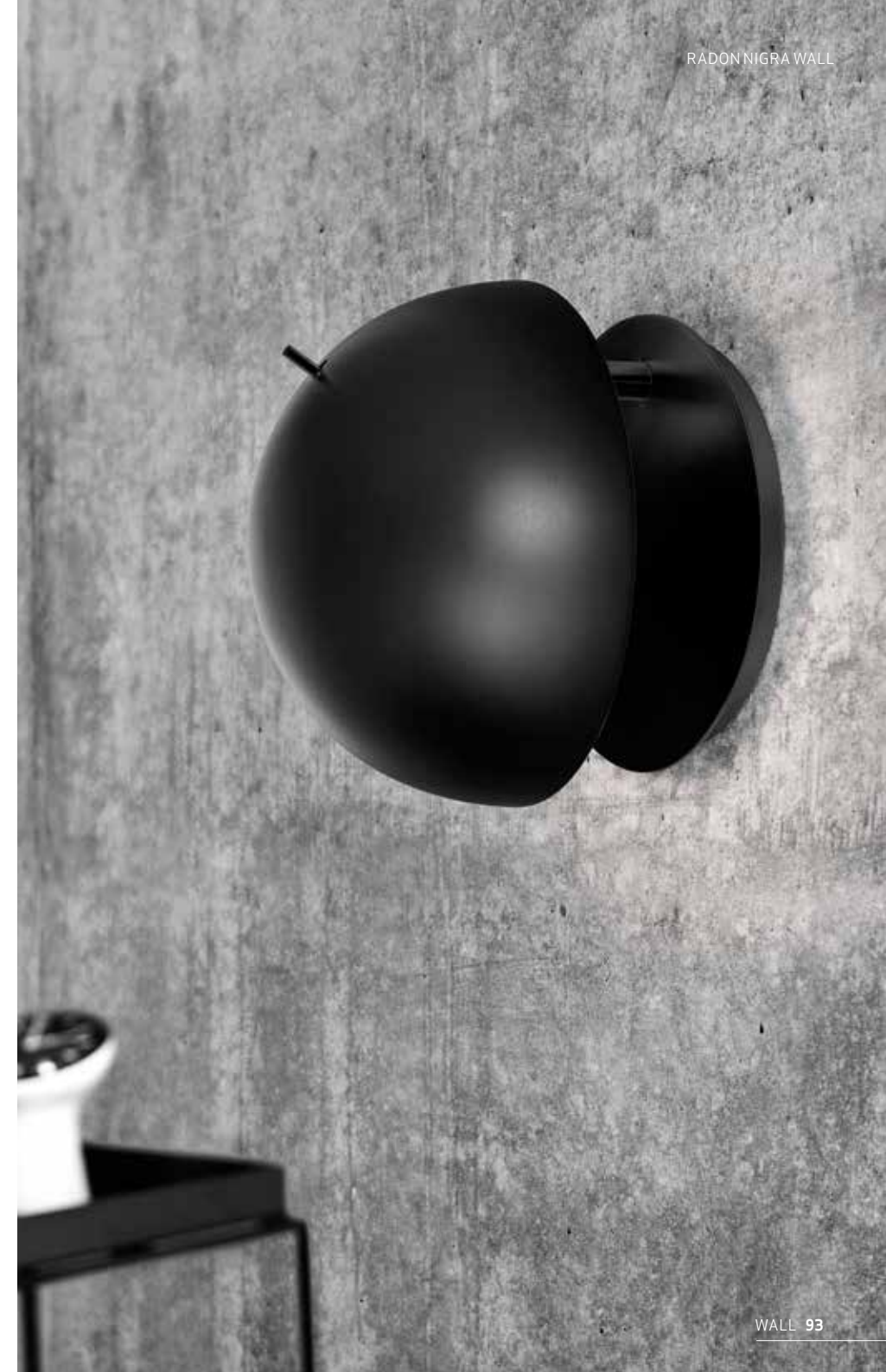





# TAKERU

DESIGN - HIDENORI KUGE 2005

Adjustable lighting is central to the design and construction of Takeru. The lamp is created around a pointed light source and a reflector that ensures maximum illumination. The specially-designed bushings allow smooth and flexible adjustment of the angle of the shade and rotation. The adjustable shade is fitted with a symmetrical reflector that softens the light.

## FACTS

**SURFACE** White lacquered, matt chrome.

**MATERIAL** Moulded steel and steel bars.

**INSTALLATION** White pvc cord.  
Cord length: 2,8 m. Switch: On cord.

**CLASS** IP20, Insulation Class II.

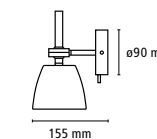

PRODUCT NAME	DESCRIPTION	LIGHT SOURCE	ENERGY LABEL
TAKERU Wall	White lacquer	G9 max 75W	A+, A, D





# OUTDOOR

---

HL | PRIMULA



HL 590 POST TOP



## HL DESIGN - HENNING LARSEN 1975

HL provides a diffuse light. The HL lamp is constructed warm-galvanized steel, untreated copper and clear/opal acrylic. In time the untreated copper shade gain the characteristic dark look and eventually it gains the classic verdigris colour. Thus the lamp grows more beautiful year after year.

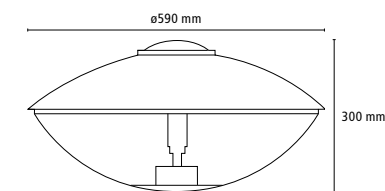
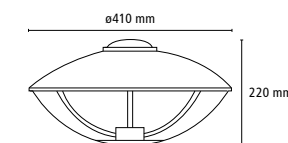
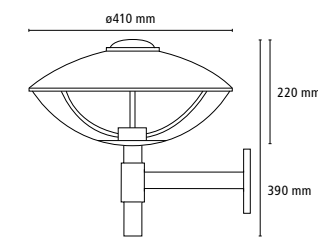

### FACTS

**SURFACE** Warm-galvanized steel, copper, clear/opal acrylic.

**MATERIAL** Top-shade: Untreated copper.

Bottom-shade: Clear/opal polycarbonate.

Wall fixture: Warm galvanized steel.

**INSTALLATION** Wall: The fixture consists of 4 parts:

Wall fixture, top-shade, bottom-shade and a steel rest.

Post top: The fixture consists of 3 parts: Top-shade, bottom-shade and a steel rest. The post top can be installed on a special pole, which can be ordered separately.

**CLASS** IP44, Insulation Class I, Vandal Class: HL 410: IK05, HL 590: IK00.



HL 410 WALL

PRODUCT NAME	DESCRIPTION	LIGHT SOURCE	ENERGY LABEL
HL 410 WALL	Ø410 mm, galvanized steel, copper, clear acrylic	E27 max 100W	A++, A+, A, B, C, D
HL 410 POST TOP*	Ø410 mm, galvanized steel, copper, clear acrylic	E27 max 100W	A++, A+, A, B, C, D
HL 410 POST TOP*	Ø410 mm, galvanized steel, copper, opal acrylic	E27 max 100W	A++, A+, A, B, C, D
HL 590 POST TOP*	Ø590 mm, galvanized steel, copper, clear acrylic	E27 max 200W	A++, A+, A, B, C, D
HL 590 POST TOP*	Ø590 mm, galvanized steel, copper, opal acrylic	E27 max 200W	A++, A+, A, B, C, D

\*Excl. pole



# PRIMULA DESIGN - KNUD HOLSCHER 2006

The Primula series is based on effective, nonglaring illumination that optimises the light from its source. Primula does this through a combination of optical elements that also utilises stray light. The basis component is a symmetrical reflector that transmits light from the source directly to the top reflector, which ensures an effective distribution. The other optical element is white reflecting rings which utilise the light that does not hit the reflector. The stray light is collected and used by the white rings without affecting the post's efficiency.

## FACTS

**SURFACE** Grey powder lacquer.

**MATERIAL** Base: Extruded aluminium, powder lacquered.  
Shade: Impact-resistant clear polycarbonate, aluminium powder lacquered.

Reflecting rings: Aluminium. In-ground spike: Warm galvanized steel  
Post-top: Zinc-alloy. Pole: Extruded aluminium.

**INSTALLATION** Bollard: The luminaire consists of three parts: Fixture head, base and spike. The base is to be fastened to an adjustable installation hardware, which is to be fastened to the spike.

Transformer/ballast: Positioned in box in base. Looping: Yes.

**CLASS** IP 65, GY 6,35: Insulation Class III, G8,5: Insulation Class I, Vandal Class:IK09.

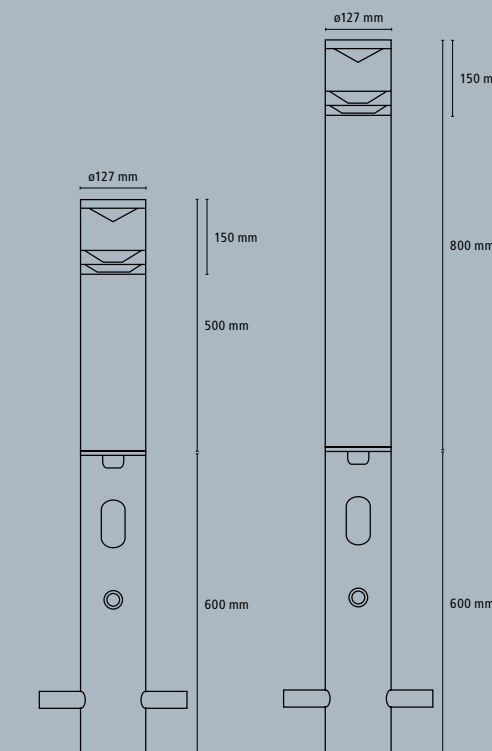

PRODUCT NAME	DESCRIPTION	LIGHT SOURCE	ENERGY LABEL	ELECTRONIC CONTROL GEAR
PRIMULA BOLLARD 1 - GY 6,35	H: 500 mm, grey powder lacquer, impact-resistant polycarbonate	GY 6,35 max 50W	C	
PRIMULA BOLLARD 2 - GY 6,35	H: 800 mm, grey powder lacquer, impact-resistant polycarbonate	GY 6,35 max 50W	C	
PRIMULA BOLLARD 1 - G8,5	H: 500 mm, grey powder lacquer, impact-resistant polycarbonate	G8,5 max 35W	A+	A2
PRIMULA BOLLARD 2 - G8,5	H: 800 mm, grey powder lacquer, impact-resistant polycarbonate	G8,5 max 35W	A+	A2
PRIMULA BOLLARD 2 w/hatch - G8,5	H: 800 mm, grey powder lacquer, impact-resistant polycarbonate	G8,5 max 35W	A+	A2



# REFERENCES

Lightyears is proud to show the fabulous installations and interiors that have been created around the world by dedicated professionals. We deeply appreciate the attention, the energy and the creativity of these gifted interior designers, lighting specialists and architects, who have handpicked our contemporary lighting products to bring out the best in their spectacular work. On the following pages we highlight a small selection of projects. Many more are featured at [www.lightyears.dk](http://www.lightyears.dk).



CASSINA SHOWROOM, PARIS  
ORIENT P1 | P2



HOTEL EBELTOFT STRAND, DENMARK  
AEON ROCKET P3 AEON-GREY



BJÖRN, MOSCOW  
CARAVAGGIO MATT P2 GREY25









SOHO LOUNGE & MUSIC BAR, HOLBÆK  
CALABASH P1 | P2 GOLD  
INTERIOR DESIGN: VESTERGAARD MØBLER HOLBÆK

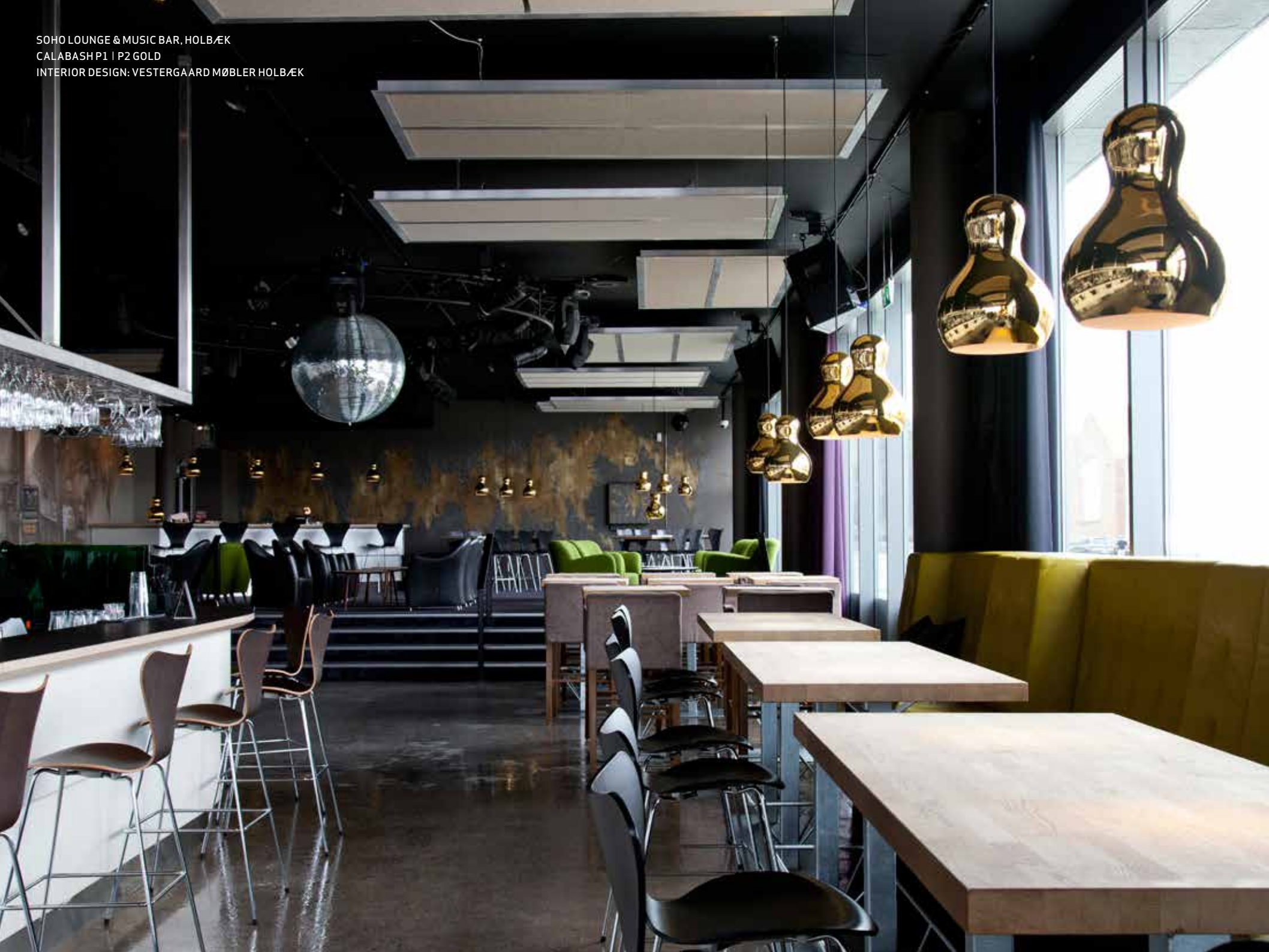

TARTINERY NOLITA, NEW YORK  
CARAVAGGIO P2 BLACK  
INTERIOR DESIGN: SOMA ARCHITECTS, NY







ALMANAK, COPENHAGEN  
MINGUS P1  
INTERIOR DESIGN: CHRISTINA MEYER BENGTSSON & HOLMBÄCKNORDENTOFT



VERANDAH, COPENHAGEN  
ORIENT P2  
INTERIOR DESIGN: GAMFRATESI



BIG, COPENHAGEN  
BULB FICTION  
INTERIOR DESIGN: BIG





BERGEN UNIVERSITY COLLEGE  
CARAVAGGIO MATT P4 GREY25  
INTERIOR DESIGN: HLM ARKITEKTUR  
PHOTO CREDIT: MAURICIO PAVEZ, CENTER FOR NEW MEDIA AT BERGEN UNIVERSITY COLLEGE



HAMAR LIBRARY AND CULTURAL CENTRE, NORWAY  
CARAVAGGIO FLOOR BLACK | P3 BLACK  
INTERIOR DESIGN: METROPOLIS ARKITEKTUR & DESIGN AS



GURU, COPENHAGEN  
ORIENT P1  
INTERIOR DESIGN: HENNING LARSEN ARCHITECTS



BOBBI BROWN, BAHRAIN  
CARAVAGGIO P2 BLACK  
INTERIOR DESIGN: ESTÉE LAUDER MIDDLE EAST







GREAT COFFEE, AARHUS  
MINGUS P1 VERY GREY | WHITE



COMFORT HOTEL EXPRESS OSLO CENTRALSTATION, NORWAY  
LULLABY P1 P2  
INTERIOR DESIGN: MINT INNREDNING, TRONDHEIM



PONCELET CHEESE BAR, BARCELONA  
ORIENT P2  
INTERIOR DESIGN: ESTUDI[H]JAC



NOHO BAR, COPENHAGEN  
ORIENT P2







BELLA SKY COMWELL, COPENHAGEN  
CALABASH P2 GOLD  
INTERIOR DESIGN: TEA (THOMAS ERIKSSON ARKITEKTER)



GORM'S FUKUOKA, JAPAN  
CARAVAGGIO P3 BLACK  
INTERIOR DESIGN: OGATA INC.





DEAN & DELUCA, ROPPONGI, TOKYO  
 CARAVAGGIO P2 WHITE  
 INTERIOR DESIGN: MASAMICHI KATAYAMA, WONDERWALL INC.



BELLAVITA HOST SHABU, TAIWAN  
 CARAVAGGIO P3 BLACK  
 INTERIOR DESIGN: SHYR-FONG HU STUDIO





HUGO BOSS CASINO, BAD URACH, GERMANY  
CARAVAGGIO P1 BLACK  
INTERIOR DESIGN: RAISER LOPES

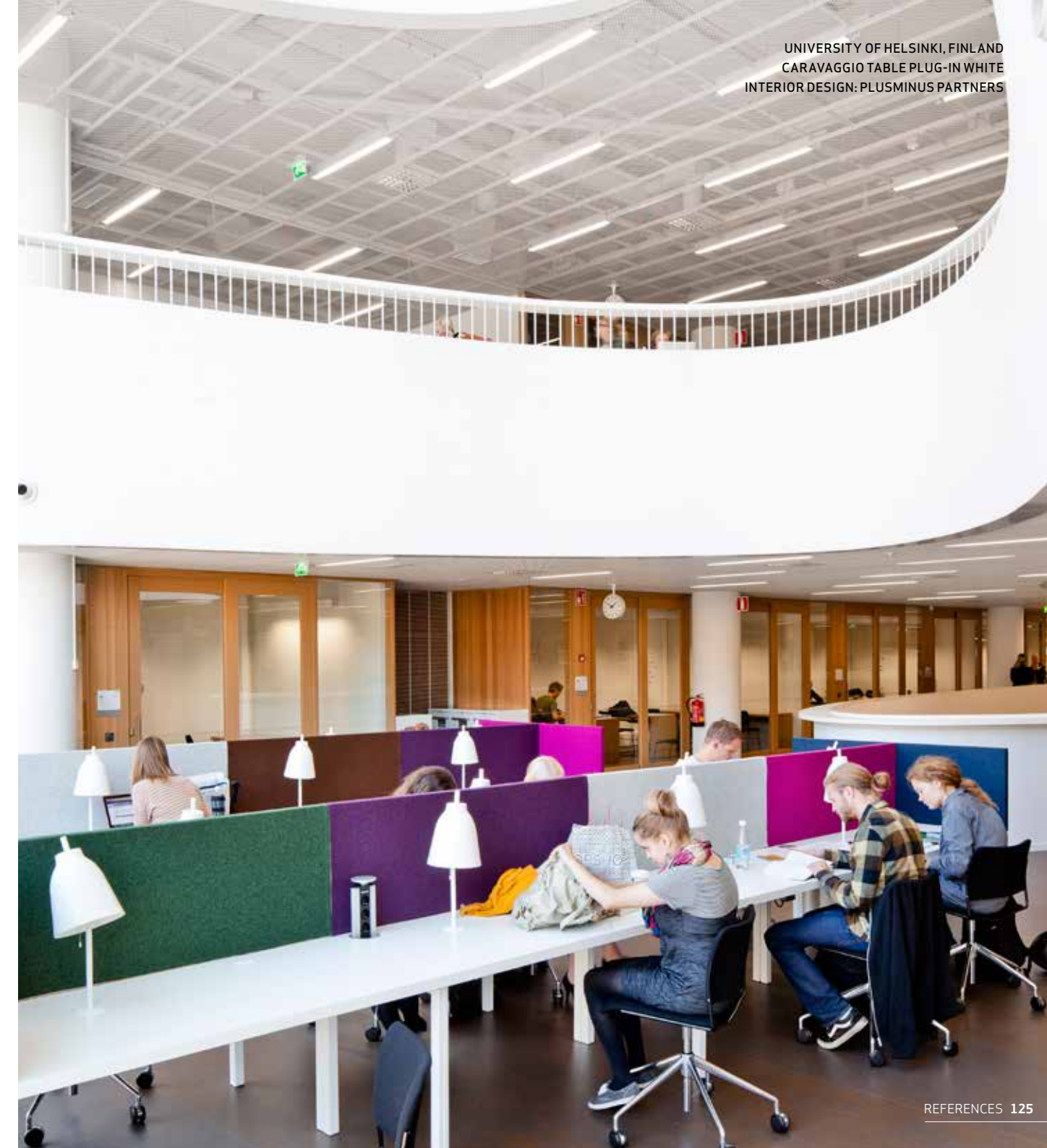

UNIVERSITY OF HELSINKI, FINLAND  
CARAVAGGIO TABLE PLUG-IN WHITE  
INTERIOR DESIGN: PLUSMINUS PARTNERS





LIGHTYEARS SHOWROOM, COPENHAGEN  
OPEN UPON AGREEMENT

GRAPHIC DESIGN: TOMMERUP & KRØYERS  
STYLING: GITTE KJÆR, PIA KRØYER, BARBARA FULGSANG GAY MANZ  
IMAGES: MIKKEL MORTENSEN, ANDERS SCHÖNNEMANN, JOACHIM WICHMANN, JOHNNY NEIGAARD, LISBETT WEDENDAHL,  
MICHAEL BERG, JASON STRONG, FRANK KLEINBACH, ANDERS BERGSTEDT, SAM CHEN, TUOMAS UUSHEIMO, JAN COOMANS,  
SARAH COGHILL, MAURICIO PAVEZ AND GERMAN CABO.  
THANKS TO SOMA ARCHITECTS, ESTÉE LAUDER MIDDLE EAST, DEAN & DELUCA, BJÖRN, MEYERS, COMFORT HOTEL EXPRESS,  
PONCELET CHEESE BAR AND HOWE FOR THE USE OF THEIR IMAGES.



LIGHT  
YEARS

**LIGHTYEARS A/S**

Balticagade 12,1  
8000 Aarhus C, Denmark  
Tel. +45 8730 1240  
info@lightyears.dk

**FOLLOW US**

[www.facebook.com/lightyears.dk](http://www.facebook.com/lightyears.dk)  
[www.twitter.com/lightyearsDK](http://www.twitter.com/lightyearsDK)  
[www.lightyears.dk](http://www.lightyears.dk)